

Cisco.300-815.v2021-03-24.q28

Exam Code:	300-815
Exam Name:	Implementing Cisco Advanced Call Control and Mobility Services
Certification Provider:	Cisco
Free Question Number:	28
Version:	v2021-03-24
# of views:	637
# of Questions views:	7768
https://www.freecram.net/torrent/Cisco.300-815.v2021-03-24.q28.html	

NEW QUESTION: 1

If all patterns below are configured in Cisco Unified Communications Manager which would be used when dialing the pattern "123"?

- A. 1XX (urgent Priority Set)
- B. 12X (urgent priority set)
- C. 12!
- D. 12[2-5]

Answer: ([SHOW ANSWER](#))

NEW QUESTION: 2

What is first preference condition matched in a SIP-enabled incoming dial peer?

- A. answer-address
- B. incoming uri
- C. incoming called-number
- D. target carrier-id

Answer: ([SHOW ANSWER](#))

NEW QUESTION: 3

Cisco SIP IP telephony is implemented on two floors of your company. Afterward, users report intermittent voice issues in calls established between floors. All calls are established, and sometimes they work well, but sometimes there is one-way audio or no audio. You determine that there is a firewall between the floors, and the administrator reports that it is allowing SIP signaling and UDP ports from 20000 to 22000 bidirectionally. What are two possible solutions? (Choose two.)

- A. Go to the SIP profile assigned to these IP phones in Cisco Unified CM and change the range of media ports to 16384-32767
- B. Ask the firewall administrator to change the range of UDP ports to 16384-32767.

- C. Ask the firewall administrator to change the ports to TCP.
- D. Go to System Parameters in Cisco Unified Communications Manager and change the range of media ports to 20000-22000.
- E. Go to the SIP profile assigned to these IP phones in Cisco Unified CM and change the range of media ports to 20000-22000.

Answer: ([SHOW ANSWER](#))

NEW QUESTION: 4

An engineer must route all SIP calls in the form of <user>@example.com to the SIP trunk gateway corporate.local. Which two SIP route patterns can be used to accomplish this task? (Choose two.)

- A. example.com@gateway.corporate.local
- B. *.*
- C. gateway.corporate.local
- D. *@example.com
- E. example.com

Answer: ([SHOW ANSWER](#))

NEW QUESTION: 5

A user reports that when they attempt to log out from the Cisco Extension Mobility service by pressing the Services button, they cannot log out. What is the most likely cause of this issue?

- A. The user device profile has not been assigned to the user.
- B. The user device profile is not subscribed to the Cisco Extension Mobility service.
- C. The Cisco Extension Mobility service has not been configured on the phone.
- D. There might be a significant delay between the button being pressed and the Cisco Extension Mobility service recognizing it. It would be best to check network latency.

Answer: ([SHOW ANSWER](#))

NEW QUESTION: 6

Which two extended capabilities must be configured on dial peers for fast start-to-early media scenarios (H.323 to SIP interworking)? (Choose two.)

- A. BFCP
- B. VIDEO
- C. FAX
- D. DTMF
- E. AUDIO

Answer: ([SHOW ANSWER](#))

NEW QUESTION: 7

When configuring hunt groups, where do you add the individual directory numbers that will be part of the group?

- A. route group
- B. hunt list
- C. line group
- D. hunt pilot

Answer: ([SHOW ANSWER](#))

NEW QUESTION: 8

Refer to the exhibit.

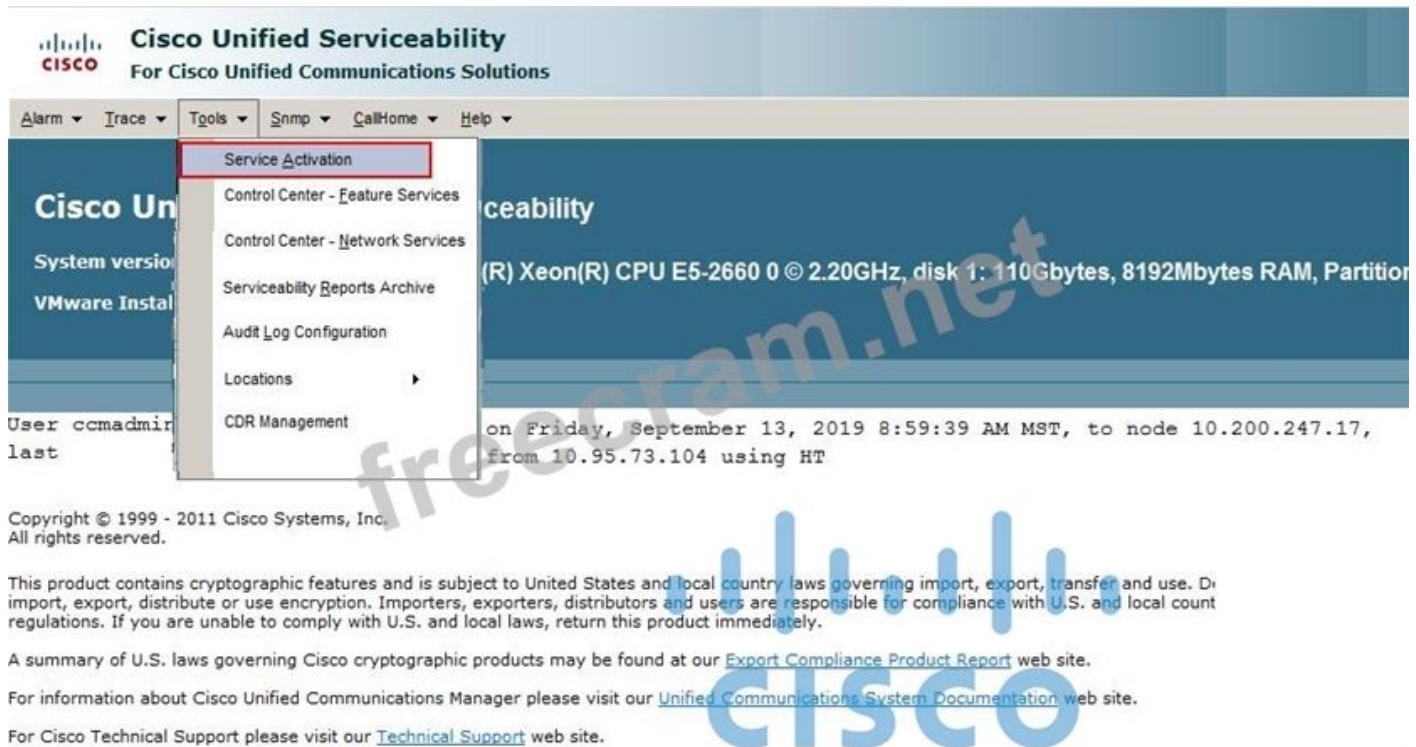

An administrator is troubleshooting a situation where a call placed from a phone registered to Cisco Unified Communications Manager does not complete. The administrator wants to use the Dialed Number Analyzer on Cisco Unified CM to check which translation pattern the call is matching. However, when logging in to Cisco Unified Serviceability there is no option for Dialed Number Analyzer under the tool menu. Which two steps must be performed to resolve this issue? (Choose two.)

- A. Activate the Cisco CallManager service.
- B. Activate the Cisco Extended Functions service.
- C. Activate the Cisco Dialed Number Analyzer Server service.
- D. Restart the subscriber
- E. Activate the Cisco Dialed Number Analyzer service.

Answer: ([SHOW ANSWER](#))

NEW QUESTION: 9

A company has an SRST gateway running an IOS XE image. The company plans to enable the IPv6 addressing companywide. To enable the IPv6 in a unified SRST gateway to support SIP

phones, what are two supported supplementary features for an IPv6 fallback scenario? (Choose two.)

- A. transcoding
- B. T.38 fax relay
- C. three-way conference
- D. secure SIP lines
- E. SIP trunk

Answer: ([SHOW ANSWER](#))

NEW QUESTION: 10

- A. The URL configured for Cisco Extension Mobility is not correct.
- B. The phone is not subscribed to Cisco Extension Mobility Service.
- C. Cisco Extension Mobility is not enabled in the Phone Configuration Window (Device > Phone)
- D. Cisco Extension Mobility Service is not running.

Answer: ([SHOW ANSWER](#))

NEW QUESTION: 11

A customer is using a SIP trunk to route calls to ITSP to decrease the possibility of downtime, the customer invested in a failover device How does the customer ensure reachability to ITSP, so that if one device on ITSP fails, the calls will be routed to another device?

- A. Enable ANAT on the SIP profile.
- B. Enable SIP Option Ping on the SIP profile.
- C. Monitor the link using network management tools, and if it fails, manually change the routing to another working device.
- D. Enable transmit security status on the SIP security profile

Answer: ([SHOW ANSWER](#))

NEW QUESTION: 12

An engineer is configuring a call park feature in Cisco Unified Communications Manager Express. Which command does the engineer use to ensure that the call is reverted to the user after 60 seconds?

- A. R2(config-ephone-dn)#park-slot timeout 60 limit 2 recall alternate 3002
- B. R2(config-ephone-dn)#park reservation-group 1
- C. R2(config-ephone-dn)#park reservation-group 60
- D. R2(config-ephone-dn)#park-slot timeout 30 limit 2 recall alternate 3002

Answer: D ([LEAVE A REPLY](#))

NEW QUESTION: 13

A user reports when they press the services key they do not receive a user ID and password prompt to assign the phone extension. Which action resolves the issue?

- A. Assign the extension as a mobile extension.

- B. Create the default device profiles for all phone models that are used.
- C. Subscribe the phone to the Cisco Extension Mobility service.
- D. Create the end user and associate it to the device profile.

Answer: C (LEAVE A REPLY)

NEW QUESTION: 14

An administrator is configuring a cluster for ILS and wants to limit the amount of entities that Cisco Unified Communications Manager can write to the database for data that is learned through ILS. Which service parameter is used to adjust this limit?

- A. Imported Dial Plan Replication Database Object Lower Limit
- B. ILS Active Learned Object Upper Limit
- C. ILS Max Number of Learned Objects in Database
- D. Global Data Service Parameter Limit

Answer: (SHOW ANSWER)

NEW QUESTION: 15

Refer to the exhibit.

Pattern	Description	Partition	Route Filter	Associated Device
41XXXX	To AMER Cluster	Global-Internal		2-AMER-RL
55XX	Rendezvous meetings	Global-Internal		Rendezvous-Conductor
9.0XXXXXXX	Local PSTN	Global-Internal		LocalDevice RL
9.911	Emergency PSTN	Global-Internal		LocalDevice RL
9.911[1-9]	Emergency PSTN	Global-Internal		LocalDevice RL

Users report that when they dial the emergency number 9911 from any internal phone, it takes a long time to connect with the emergency operator. Which action resolves this issue?

- A. Adjust the service parameter T302 timer to the desired value.
- B. Point the emergency pattern directly to the PSTN gateway.
- C. Check the Urgent Priority check box under 9.911 pattern.
- D. Adjust the service parameter T204 timer to the desired value.

Answer: C (LEAVE A REPLY)

NEW QUESTION: 16

An administrator is implementing a new dial-plan on Cisco Unified Border Element. The administrator must ensure that incoming dial-peers are matched based on the IP address from where the incoming request originates. Which dial-peer configuration should be applied to accomplish this requirement?

- A. dial-peer voice 1 voip
incoming called-number
- B. dial-peer voice 1 voip
incoming url to
- C. dial-peer voice 1 voip

incoming url request

D. dial-peer voice 1 voip

incoming url via

Answer: D ([LEAVE A REPLY](#))

Valid 300-815 Dumps shared by ExamDiscuss.com for Helping Passing 300-815 Exam! ExamDiscuss.com now offer the **newest 300-815 exam dumps**, the ExamDiscuss.com 300-815 exam **questions have been updated** and **answers have been corrected** get the **newest** ExamDiscuss.com 300-815 dumps with Test Engine here:

<https://www.examdiscuss.com/Cisco/exam/300-815/premium/> (243 Q&As Dumps, **35%OFF**

Special Discount Code: [freecram](#))

NEW QUESTION: 17

The Cisco Unified Communications Manager Dialed Number Analyzer allows analysis of calls from which two devices? (Choose two.)

A. translation patterns

B. CTI ports

C. IP phones

D. device pools

E. CTI route points

Answer: ([SHOW ANSWER](#))

NEW QUESTION: 18

Refer to the exhibit.

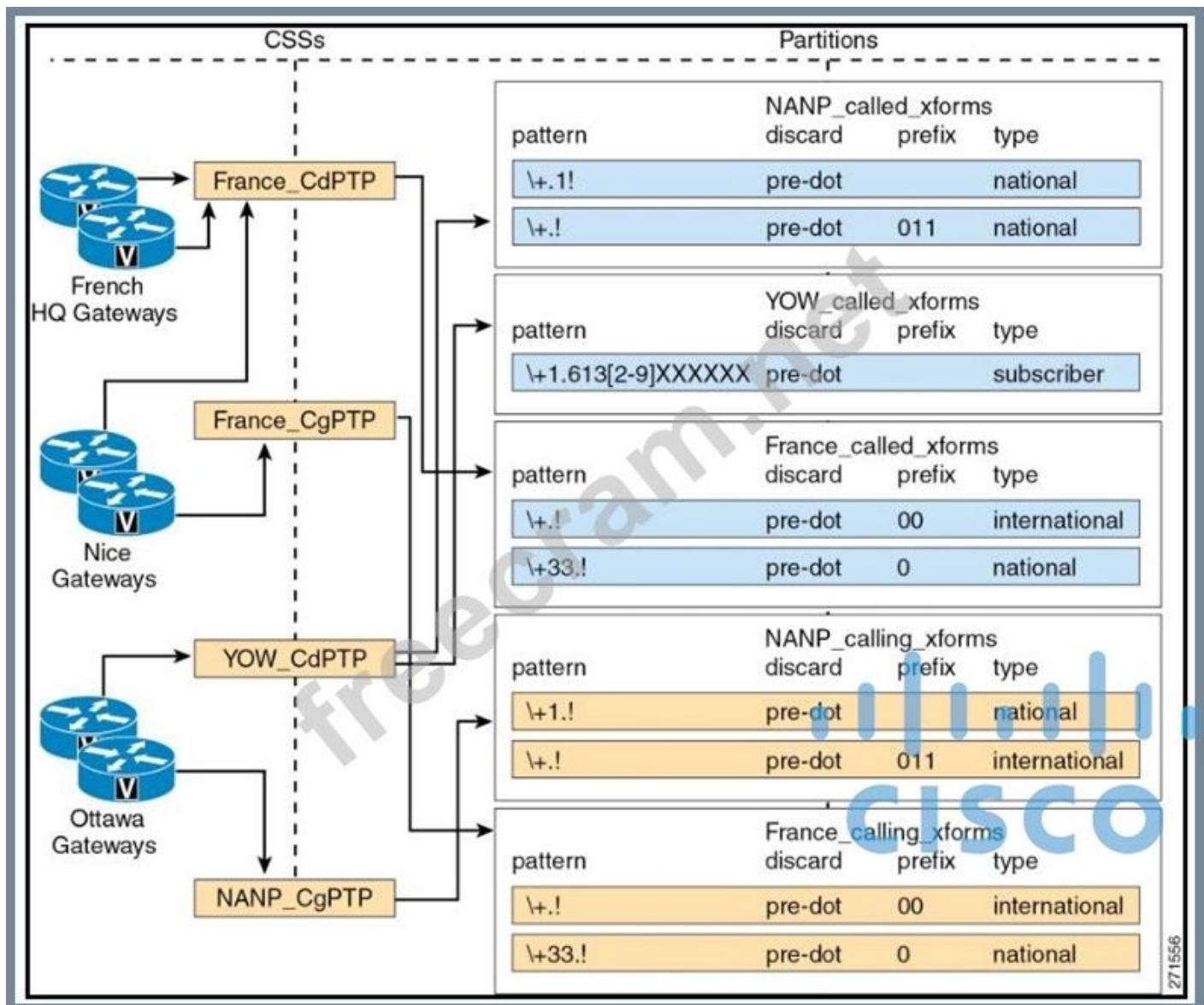

Within the North American Numbering Plan, gateways located in Ottawa, Canada and marked as "YOW" are assigned to the Calling Party Transformation CSS NANP_CgPTP, which contains partition NANP_calling_xforms. What is the calling-party number and the numbering type if the calling user +1613-555-1234 dials the number?

- A. calling number 613-555-1234 and numbering type "subscriber"
- B. calling number 011-1-613-555-1234 and numbering type "subscriber"
- C. calling number 011613-555-1234 and numbering type "international"
- D. calling number 613-555-1234 and numbering type "national"

Answer: (SHOW ANSWER)

NEW QUESTION: 19

The administrator of ABC company is troubleshooting a one-way audio issue for a call that uses H.323 protocol (slow-start mode). The administrator requests that you provide the IP and port information of the Real-Time Transport Protocol traffic that had the one-way audio call.

You gather the H.225 and H.245 messages for one of the one-way audio calls. Where can you find the RTP IP and port information for both sides? (Note: This call flow has not invoked any media resources like MTP or transcoders).

- A. H.245 Terminal Capability Set
- B. H.245 Open Logical Channel
- C. H.225 Connect
- D. H.245 Open Logical Channel Ack

Answer: ([SHOW ANSWER](#))

NEW QUESTION: 20

Refer to the exhibit.

```
!  
dial-peer voice 1 voip  
description to ITSP  
destination-pattern 555.....  
session target ipv4:209.110.110.1  
incoming called-number .  
codec g711ulaw  
!  
!
```

An engineer configures Cisco Unified Border Element to connect the enterprise VoIP network with a SIP telephony provider. Calls are not working in either direction. What must be configured in the dial peer 1 to fix the issue?

- A. session-protocol sipv2
- B. incoming called number 555.....
- C. codec g729
- D. answer-address 555

Answer: ([SHOW ANSWER](#))

NEW QUESTION: 21

Due to a shortage of physical interfaces on a device the administrator requires that a loopback for RTP is used. Which command is required when using a loopback interface for RTP?

- A. voice-class sip resources priority mode passthrough
- B. voice-class sip bind media source-interface Loopback0
- C. voice-class sip bind control source-interface Loopback0
- D. voice-class sip early-offer forced.

Answer: ([SHOW ANSWER](#))

NEW QUESTION: 22

Which two statements are correct with respect to the Client Matter Code setting in the route pattern configuration? (Choose two.)

- A. The Client Matter Code has the option to configure Authorization Level such as in the Forced Authorization Code.
- B. If you check the Allow Overlap Sending check box, you can also check the Require Client Matter Code check box.
- C. The Client Matter Code feature does support overlap sending because the Cisco Unified Communications Manager can determine when to prompt the user for the code.
- D. The Client Matter Code feature does not support overlap sending because the Cisco Unified CM cannot determine when to prompt the user for the code.
- E. If you check the Allow Overlap Sending check box, the Require Client Matter Code check box becomes disabled.

Answer: ([SHOW ANSWER](#))

NEW QUESTION: 23

Which action is correct with respect to toll fraud prevention configuration in the Cisco Unified Communications Manager Express?

- A. Configure IP Address Trusted Authentication for Incoming VoIP Calls.
- B. Configure Direct Inward Dial for Incoming ISDN Calls with overlap dialing.
- C. Configure the command no ip address trusted authenticate under "voice service voip".
- D. Enable Secondary Dial tone on Analog and Digital FXO Ports.

Answer: ([SHOW ANSWER](#))

NEW QUESTION: 24

Which two configuration parameters are prerequisites to set Native Call Queuing on Cisco Unified Communications Manager? (Choose two.)

- A. Cisco RIS data collector service must be running on the same server as the Cisco CallManager service.
- B. Cisco IP Voice Media Streaming Service must be activated on at least one node in the cluster.
- C. The maximum number of callers allowed in queue must be 10.
- D. A unicast music on hold audio source must be configured.
- E. The phone button template must have the Queue Status Softkey configured.

Answer: ([SHOW ANSWER](#))

NEW QUESTION: 25

Refer to the exhibit.

Calls incoming from the provider are not working through newly set up Cisco Unified Border Element. Provider engineers get the 404 Not Found SIP message. Incoming calls are coming from the provider with called number "222333444" and Cisco Unified Communications Manager is expecting the called number to be delivered as "444333222". The administrator already verified

that the IP address of the Cisco Unified CM is set up correctly and there are no dial peers configured other than those shown in the exhibit. Which action must the administrator take to fix the issue?

- A. Set up translation-profile on the incoming dial peer to match incoming traffic.
- B. Fix the voice translation-rule to match specifically number "222333444" and change it to "444333222".
- C. Create specific matching for "222333444" on the incoming dial peer.
- D. Change the destination-pattern on the outgoing dial peer to match "444333222".

Answer: ([SHOW ANSWER](#))

NEW QUESTION: 26

Which top-level IOS command is needed to begin the configuration of a Cisco Unified Communications Manager Express gateway to enable phones to be registered via SIP?

- A. voice register dn
- B. voice register global
- C. voice service voip
- D. allow-connections sip to sip

Answer: ([SHOW ANSWER](#))

NEW QUESTION: 27

Configure Call Queuing in Cisco Unified Communications Manager. Where do you set the maximum number of callers in the queue?

- A. in Cisco Unified CM Enterprise Parameters
- B. in Cisco Unified CM Service Parameters
- C. in the queuing configuration
- D. in the telephony service configuration

Answer: ([SHOW ANSWER](#))

NEW QUESTION: 28

Refer to the exhibit.

Users report that when they dial to Cisco Unity Connection from an external network, they cannot enter any digits. Assuming only in-band DTMF is supported, what is a reason for this malfunction?

- A. The rtpmap:0 value for the negotiated codec is marking DTMF as inactive.
- B. There is SIP Delayed Offer. DTMF is supported only in Early Offer.
- C. No DTMF is negotiated.
- D. The negotiated RTP port is outside of the range described by RFC, so inband DTMFs do not work.

Answer: ([SHOW ANSWER](#))

Valid 300-815 Dumps shared by ExamDiscuss.com for Helping Passing 300-815 Exam!
ExamDiscuss.com now offer the **newest 300-815 exam dumps**, the ExamDiscuss.com
300-815 exam **questions have been updated** and **answers have been corrected** get the
newest ExamDiscuss.com 300-815 dumps with Test Engine here:

<https://www.examdiscuss.com/Cisco/exam/300-815/premium/> (**243** Q&As Dumps, **35%OFF**

Special Discount Code: freecram)